



WINPOD 2.0
REDEFINE YOUR WORKING SPACE



EXTENDABLE DESKTOP



WINPOD FOR THE WIN

Choose wisely and outsmart your competitors to achieve better results.

WINPOD 2.0 now comes with amazing features, offering the most advantageous combination of cost, quality and sustainability to improve satisfaction and work performance.

WINPOD 2.0 pairs finely crafted aesthetics with sustainable materials to protect our mother earth. Its sound insulation effects have been tested by international certification organization, reflecting WINPOD's ingenuity and WINTECH's endeavour in creating a workspace that improves productivity and privacy.

EXCELLENT AESTHETIC DESIGNS

Air Purifying System with HEPA Filter. The pod is well ventilated with filtered air to provide a comfortable and clean workspace to the user. **NEW**

Motion Sensor for Energy Saving. LED lighting and air ventilation system are activated by the motion sensor, and will be automatically turned off after 5 minutes of inactivity.

Ergonomic and Exclusive Charging Ports. CE certified charging ports with AC outlet, type A / type C 45W PD and CAT6 port. Input 110-240 VAC, 10A, 50-60Hz. **NEW**



Acoustic Material for Sound Insulation. The speech level reduction in the pod offers private and quiet environment, to be free from disturbances.

Auto Close Tempered Glass Door. The door can only be opened up to 95° to prevent collision against surroundings. **NEW**

Elegant Door Handle. Trendy and aesthetic designs making WINPOD 2.0 an elegant component to the surroundings. **NEW**

Knockout Hole for Sprinkler. Sprinkler head can be installed based on safety requirement.

Castors for The Ease of Mobility. An add-on feature for S/W/D POD 2.0. *Optional **NEW**

Quick And Easy To Assemble. Improved design which makes installation time possible within 30 minutes.



ELEGANT DOOR HANDLE

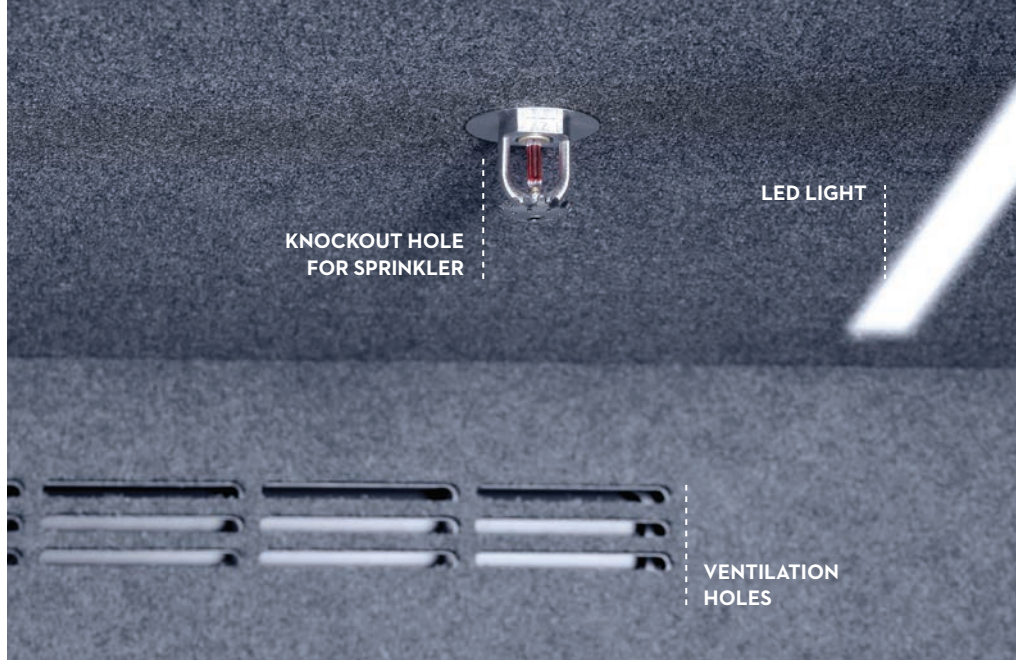

KNOCKOUT HOLE FOR SPRINKLER

LED LIGHT

VENTILATION HOLES



DIMMER

TYPE A / TYPE C

AC OUTLET



**ENERGY
EFFICIENT**



**DESIGNED
WITH
INGENUITY**







HIGH ACOUSTIC RATING

RECYCLE & SUSTAINABLE

Acoustic Material: Crafted To Perfection

WINPOD 2.0 adopts 100 percent polyester, non-poisonous, harmless, non-irritant, and odourless acoustic material which offers excellent sound absorption. Most importantly, the acoustic materials are harmless to the environment because they can be recycled and reused.

The sound absorption alongside the quality, recyclability and reusability of the acoustic material have also been tested by the relevant testing boards. WINPOD 2.0 aims to put sustainability and societal impact at the heart of all its endeavours.



Prioritising “Green” Manufacturing Materials

WINTECH strives to create green, resilient and competitive products. Taking the manufacturing materials of S POD 2.0 as an example, galvanized steel makes up 78 percent of the materials used. This can reduce the environmental burden to the planet earth and is in line with the ideal of sustainable development.

S POD 2.0

- Acoustic Material
- Aluminium
- Glass
- Wood
- Others
- Electro Galvanized Steel

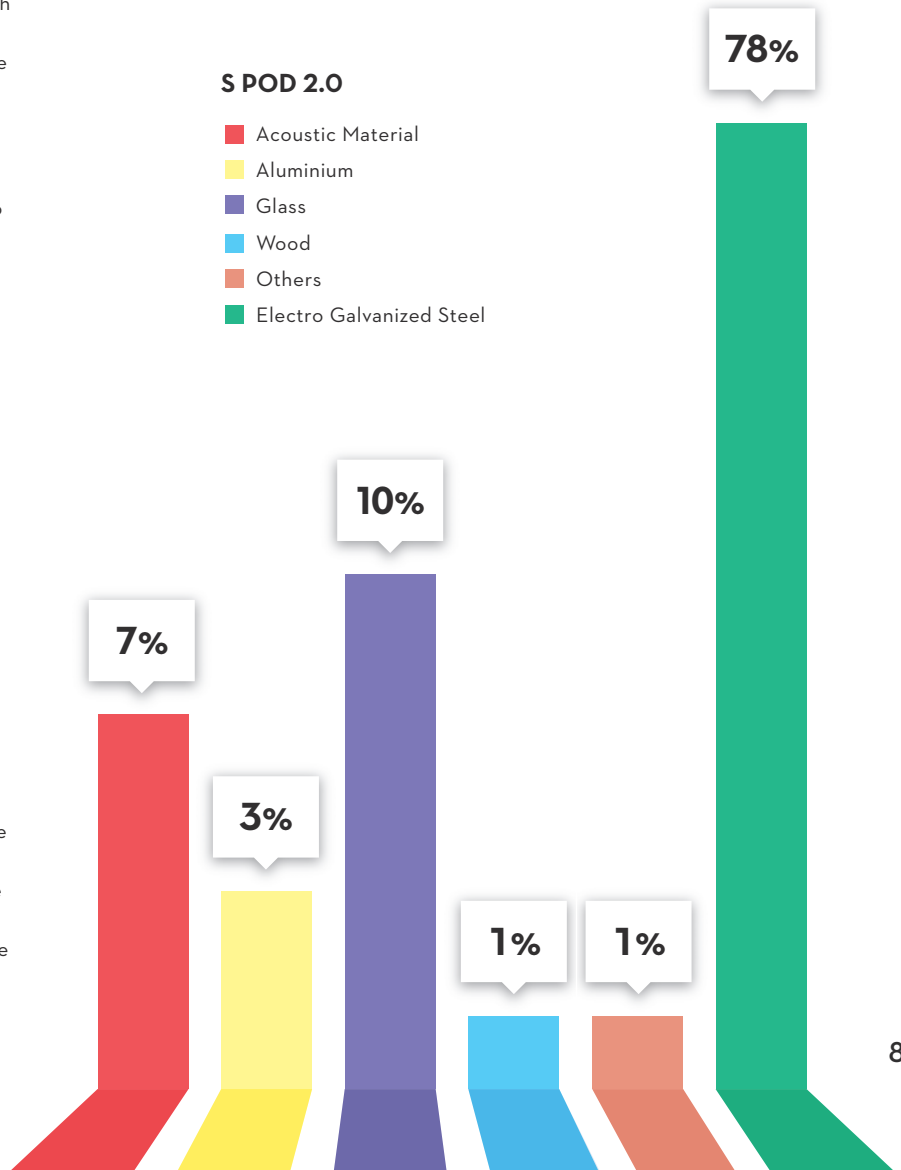

PEACE WITH SOUND INSULATION

We Care For Your Well-Being

In an environment with sound level is above 70 dB, you will soon find yourself difficult to remain focused and productive at work.

WINPOD 2.0 has gone through rigorous test based on ISO 23351-1 standards, with the speech level reduction at 28.3 dB. It creates a serene and relaxing environment that counters the stress and anxiety of our daily grinds. WINPOD 2.0 not only provides more opportunities for creative collaboration, but also helps to maximize users' concentration and satisfaction, as well as enjoy the quiet moment.

Aside from sound insulation, WINPOD 2.0 has achieved GREENGUARD Certification which is scientifically proven to meet some of the world's most rigorous third-party chemical emissions standards, helping to reduce indoor air pollution and the risk of chemical exposure. The certification can contribute to LEED credits as well.

Certified by



HIGH ACOUSTIC RATING

D_{S,A} - 28.3 dB

Based on ISO 23351-1 standard



**UL GREENGUARD
CERTIFIED**



**HIGHEST
QUALITY**





COMFORTABLE AND BREATHABLE



CLEAN AIR* IN WINPOD 2.0

WINPOD 2.0 utilizes a top-notch air ventilation and air purifying technology to provide consumers a pleasant breathing environment.

The air ventilation system enables a high enough air exchange rate within the pod to provide a comfortable and healthy working environment.

Additionally, the included HEPA filter captures airborne particles to cleanse entering air and enhance air quality. It inadvertently lessens allergic responses.

The filtered air was tested based on ISO 14644-1:2015 standard.

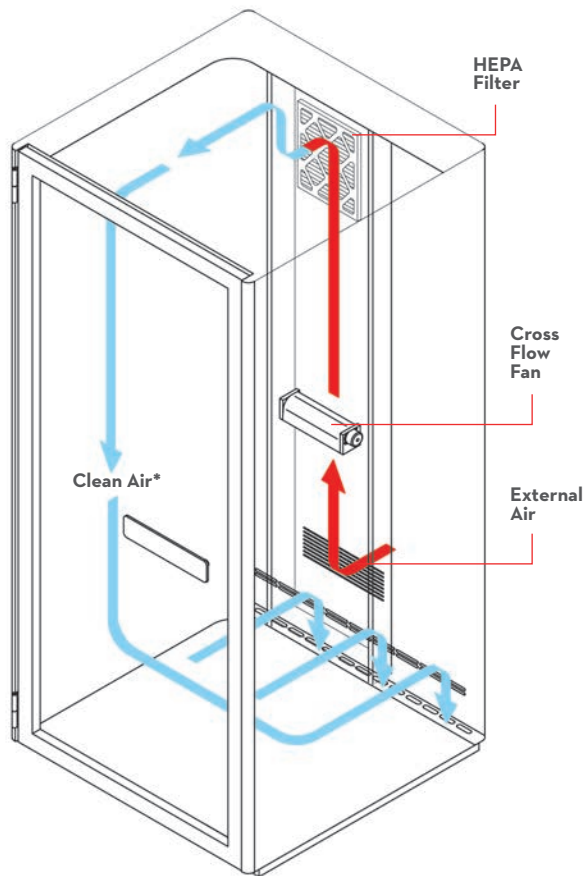

Model	Airflow (m ³ /h)	Air Change Per Hour (ACH)
S POD 2.0	131	81
W POD 2.0	131	37
D POD 2.0	262	59
C POD 2.0	393	43
M POD 2.0	393	31

*Air cleanliness by particle concentration

WINPOD 2.0

Acoustic Pod has now emerged to become a popular office furnishing product in the global market. WINPOD 2.0 offers a new experience for workspace. A Serene, comfortable and practical solution to improve work efficiency. Comes in five models to suit the needs of different users.



S POD 2.0

S POD 2.0 is a classic pod for single person. In the serene space, an individual can carry out works that require high level of privacy such as signing contracts, making phone calls, and video conference.

* High stool not included.

W POD 2.0

W POD 2.0 has a unique extendable desktop with multiple functions. This ergonomic feature allows you to adjust your working position, while providing a storage space. This spacious pod is suitable for individual who wants to work over a long period of time.

D POD 2.0

D POD 2.0 can accommodate two to four persons. The sofas come with comfortable backrest allow users to carry out discussions in a relaxed manner, most importantly free from disturbance. Aiming to achieve satisfaction and better results.



C POD 2.0

C POD 2.0 is designed to fit up to five people, ideally for meeting, entertainment or relaxing. The meeting table with integrated charging ports are perfect for discussion and brainstorming. Choice of L-shaped sofa offers a casual yet private moments for folks.

* Side table and TV not included



M POD 2.0

M POD 2.0 can accommodate up to seven persons. Its comfortable and well-ventilated space can help users to increase work efficiency and productivity.

Apart from the meeting table and L-shaped sofa, a bare unit is also available for your personal option to furnish it.

*Chairs and TV not included

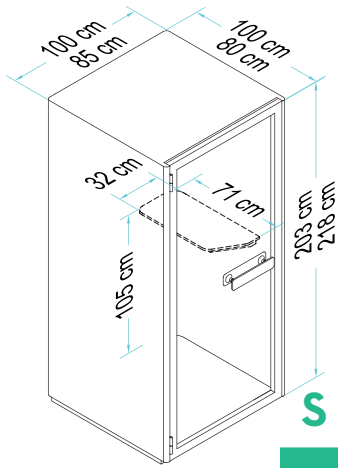

S POD 2.0

1. Laminated Desktop
2. Castor **Optional*
3. Power Consumption: 0.18 A
4. Net Weight: 278 kg

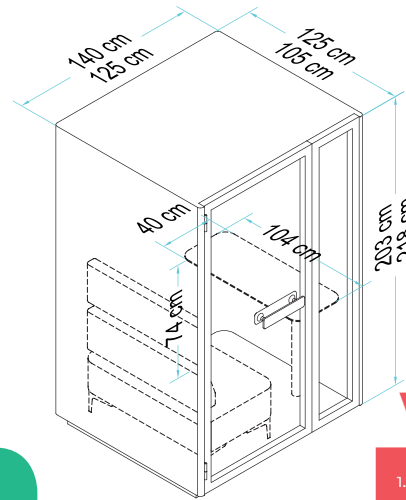

W POD 2.0

1. Extendable Desktop With Storage Space
2. Exclusive Design Of Sofa With Backrest
3. Castor **Optional*
4. Power Consumption: 0.18 A
5. Net Weight: 405 kg

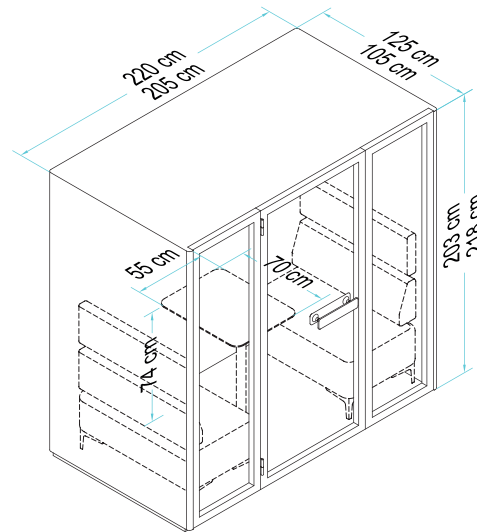

D POD 2.0

1. Laminated Desktop
2. Exclusive Design Of Sofa With Backrest
3. Castor **Optional*
4. Power Consumption: 0.33 A
5. Net Weight: 532 kg



**QUICK
AND
EASY TO
ASSEMBLE**

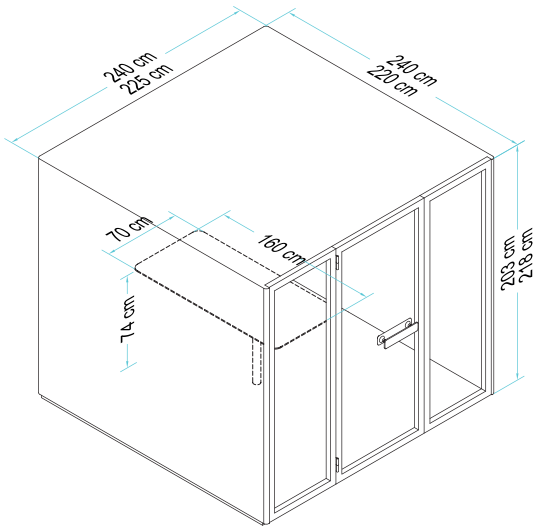
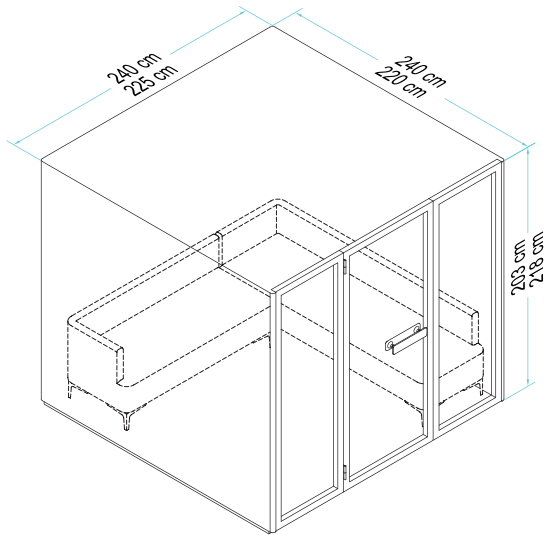

C POD 2.0

1. Selections Of Furnishing:
 - Exclusive L-Shaped Sofa
 - Meeting Table With Integrated Charging Ports
 - Bare Unit
2. TV Bracket With AC Power Socket **Optional*
3. Power Consumption: 0.47 A
4. Net Weight: 893 kg

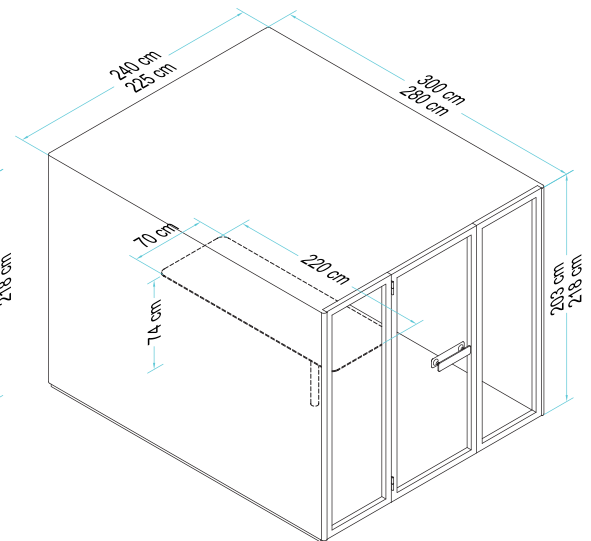
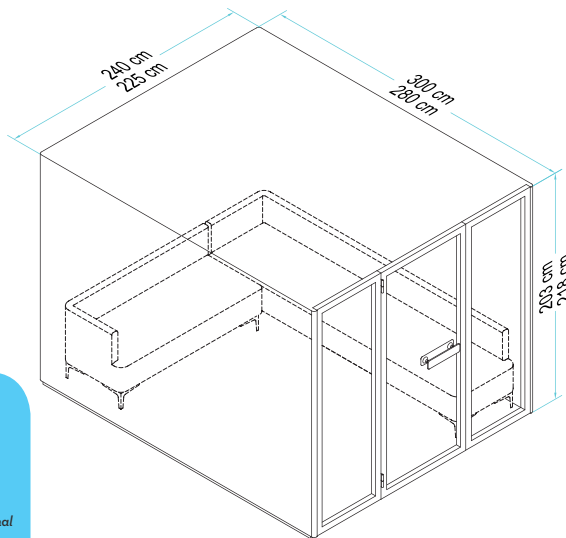

M POD 2.0

1. Selections Of Furnishing:
 - Exclusive L-Shaped Sofa
 - Meeting Table With Integrated Charging Ports
 - Bare Unit
2. TV Bracket With AC Power Socket **Optional*
3. Power Consumption: 0.47 A
4. Net Weight: 967 kg

EXTERIOR

COLOUR SELECTION



Smoke White



Charcoal Black



Silver



Space Grey



Sky Blue



Lagoon Blue



Rose Pink



Dandelion Yellow

INTERIOR

ACOUSTIC SHEET COLOUR SELECTION



Light Grey

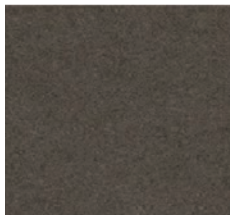

Charcoal Black

CARPET COLOUR SELECTION



Black



Silver (M POD Only)

SOFA

FABRIC COLOUR SELECTION



1001
Oyster White



1002
Beige Grey



1003
Brown Grey



1006
Dark Grey



1007
Grey



1009
Brown



1011
Yellow



1014
Dark Green



1015
Blue



1016
Dark Blue



1020
Orange



1021
Purple



1022
Peach

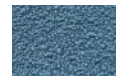

1023
Sky Blue



1026
Lemon Yellow



1027
Brown Red

*Display colours may slightly vary from the actual colours.

**ALL RIGHTS RESERVED BY:
MALAYSIA 18-01096-0101**

ABOUT THE COMPANY

2001

Founded in 2001. WINTECH Metal Processing Sdn Bhd specializes in original equipment manufacturing (OEM) and original brand manufacturing (OBM), offering quality household and office steel storage.

2014

Moved to its first wholly-owned factory which has a built-up area of 280,000sq. ft.

2017

WINTECH has emerged as a well-known industry leader in both local and international markets. Received stable orders for OEM and exported products to more than 20 countries in Southeast Asia, Oceania, Middle East, Europe and North America.

2018

WINTECH's first Acoustic Pod was born. It was the first acoustic pod made of steel in Malaysia. The product was unveiled in various trade expos around the world.

2020

WINPOD successfully established itself within two years. It gained traction in Asian and European markets, and became a sought-after product among customers from Southeast Asia, Asia, Oceania, Middle East, Europe and America.

2022

WINPOD 2.0 was launched, offering new elements, functional designs and significant improvements to its users.

WINTECH®

CONTACT



ADDRESS

WINTECH METAL PROCESSING SDN BHD
180, Jalan 5, Kompleks Perabot
Olak Lempit, 42700 Banting
Selangor, Malaysia



PHONE & FAX

General Line +603 3149 2377
Fax +603 3149 1091
(Sales & Marketing)
Direct Line +6012 202 7008 (Dixon)
+6012 618 6671



ONLINE

Email enquiries@wintech.com.my

www.wintech.com.my



Scan to get a
digital copy